

## Označení dílů

M – fotoleptané kovové díly  
D - obtisky  
? - volba

## Parts labelling

M – photoetched parts  
D - decals  
? - option

### Poznámka

Díl č. M61 nepoužívejte.

### Notice

Do not use part No. M61.

### Návod ke stavbě

Při stavbě postupujte podle instruktážních obrázků.

Fotografie ze stavby modelu najdete na  
[www.plusmodel.cz](http://www.plusmodel.cz) v sekci gallery

### Instructions

Follow the instruction drawings the assembly.

Photos of model buiding you can find  
on [www.plusmodel.cz](http://www.plusmodel.cz) in Gallery section

**Upozornění:** Během opracování může vznikat prach, který může dráždit dýchací cesty. Používejte ochranu očí při odšťihování kovových dílů.

**Notice:** Machining can produce dust witch can be irritating to the respiratory tract. Metal parts should be cut off using protection eyesight.

**Kupujte přímo na [www.plusmodel.cz](http://www.plusmodel.cz)**  
**Buy directly from [www.plusmodel.cz](http://www.plusmodel.cz)**

Plus Model s.r.o.  
Jižní 56, 370 10 České Budějovice  
Czech Republic  
<http://www.plusmodel.cz>  
e-mail: [plusmodel@plusmodel.cz](mailto:plusmodel@plusmodel.cz)

# 342

# plusmodel

# 1/35

## PRAGA RV

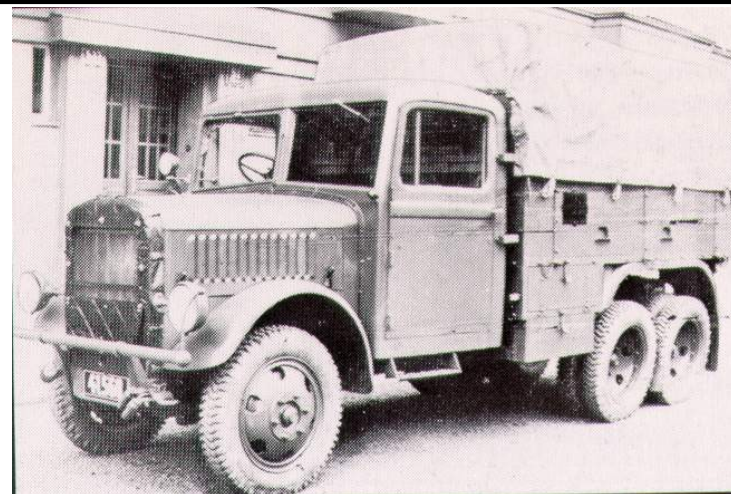

### Historie

Praga RV byl 2 tunový nákladní automobil s pohonem 6x4. Byl vyráběn v letech 1935 - 1940, nejprve pro Československou armádu, později byl používán i Německou armádou a jednotkami Osy. V roce 1939 byla vyráběna i varianta radiovozu označená RVR. Celkem bylo vyrobeno 4290 ks vozů RV a 39 vozů RVR.

### Technická data

Motor - zážehový, kapalinou chlazený šestiválec  
zdvihový objem 3462 ccm  
maximální výkon 44,1 kW (60 hp)  
Převodovka - 4 stupně vpřed, 1 stupeň vzad  
Celková hmotnost 3810 kg

### History

Praga RV was a 2 Ton lorry with 6 x 4 drive. It was developed from 1935 to 1940 for Czechoslovakia army, later it was used by German and Axis units. In 1939 was produced as radiocar version marked RVR. In all was 4290 vehicles of variant RV and 39 vehicles of variant RVR.

### Technical data

Engine: 6 cyl. spark ignition liquid-cooled engine  
3,462 ccm  
max. 44,1 kW (60 HP)  
4-speed gearbox plus reverse gear  
Total weight 3,810 kg

## COLOR

All chassis inclusive engine and gearbox is in czech khaki color

Celý podvozek včetně motoru a převodovky je v barvě khaki.

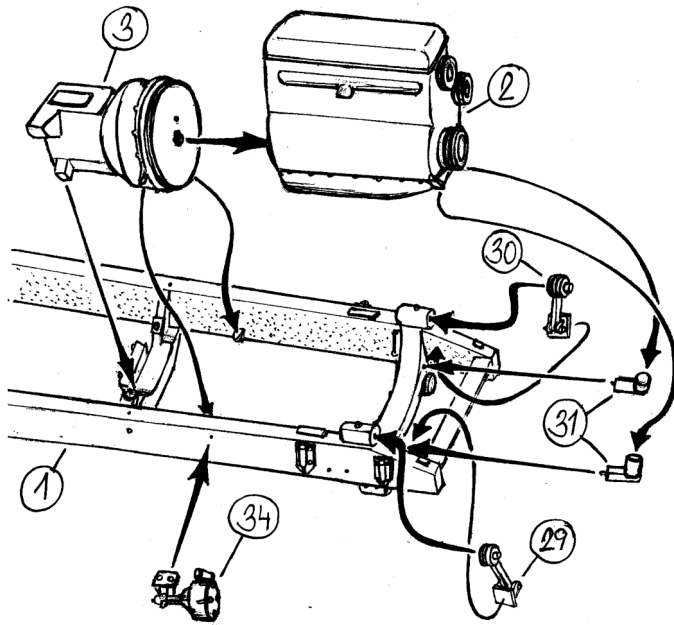

1

2

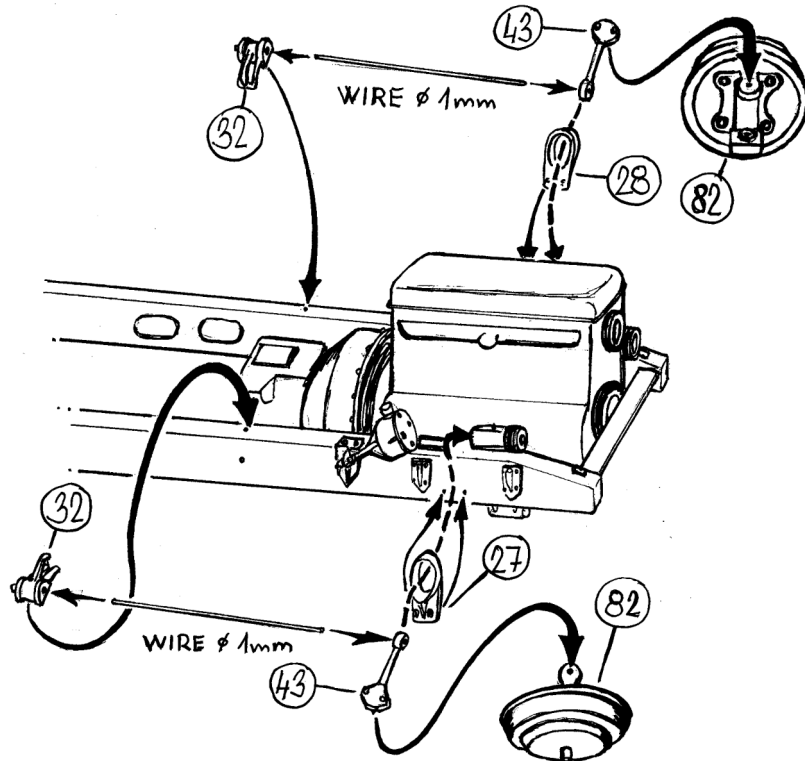

## Camoufalge

### I..Czechoslovakia army

All vehicle was painted Czech khaki color.

Headlights, run boards, tablets on sides of body and horn were gloss black.

Front signplate decal No. D1 or D3, rear signplate decal No.D2 or D4.

### I. Československá armáda

Celé vozidlo je v barvě khaki. Světlomety, stupačky, tabulky na boku korby a houkačka jsou leskle černé.

Přední značka obtisk č. D1 nebo D3, zadní značka obtisky D2 nebo D4

### II. German Wehrmacht

All vehicle was in german Panzer grey.

Corners of front and rear mudguards had white edging.

Decals No.D7 were on left front and left rear mudguards.

### II. Wehrmacht – Německo

Celé vozidlo v německé tmavé šedé Panzer grey.

Rohy předních i zadních blatníků jsou lemovány bíle.

Obtisk č. D7 (označení jednotky) je na levém předním a levém zadním blatníku.

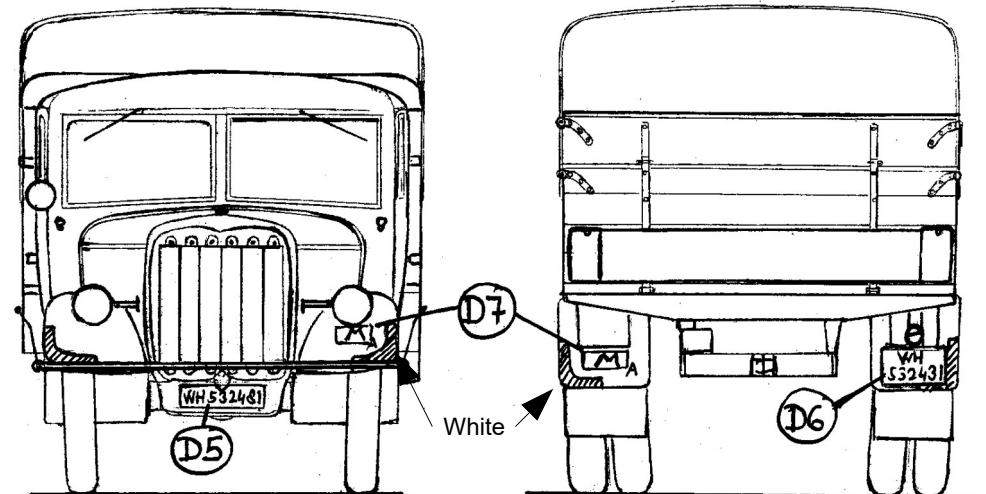

30

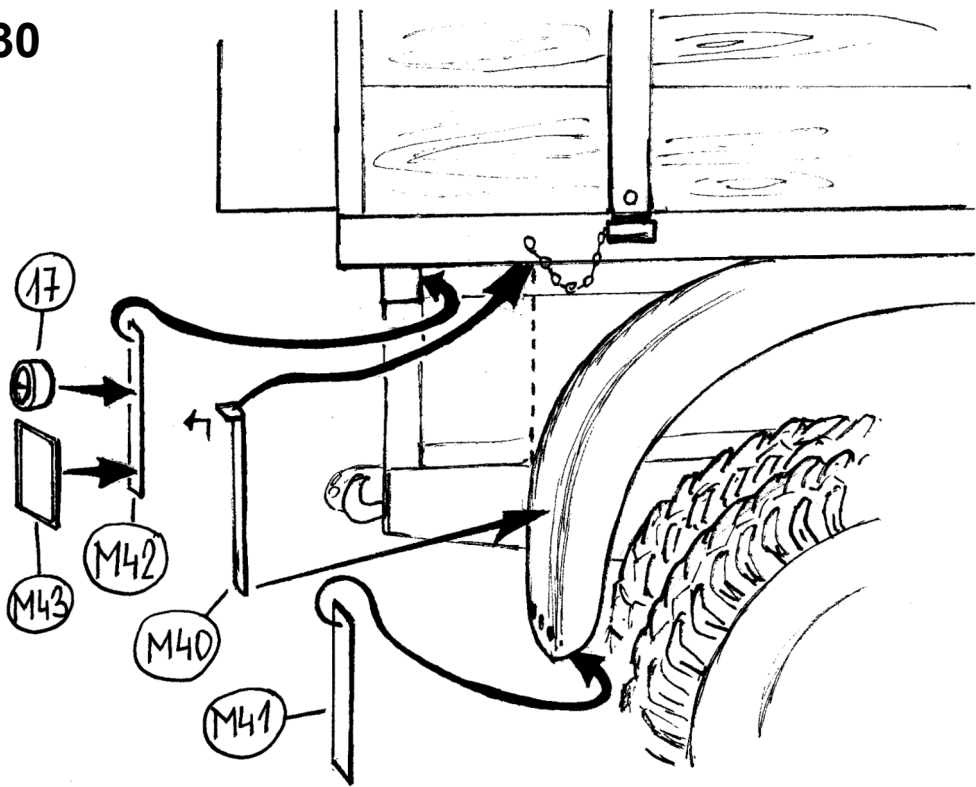

31

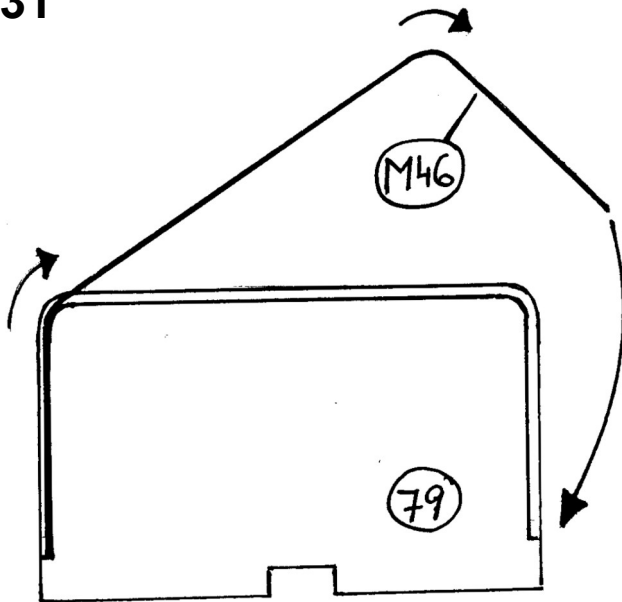

Bending jig for parts No.M46

Ohybací šablona pro díly M46

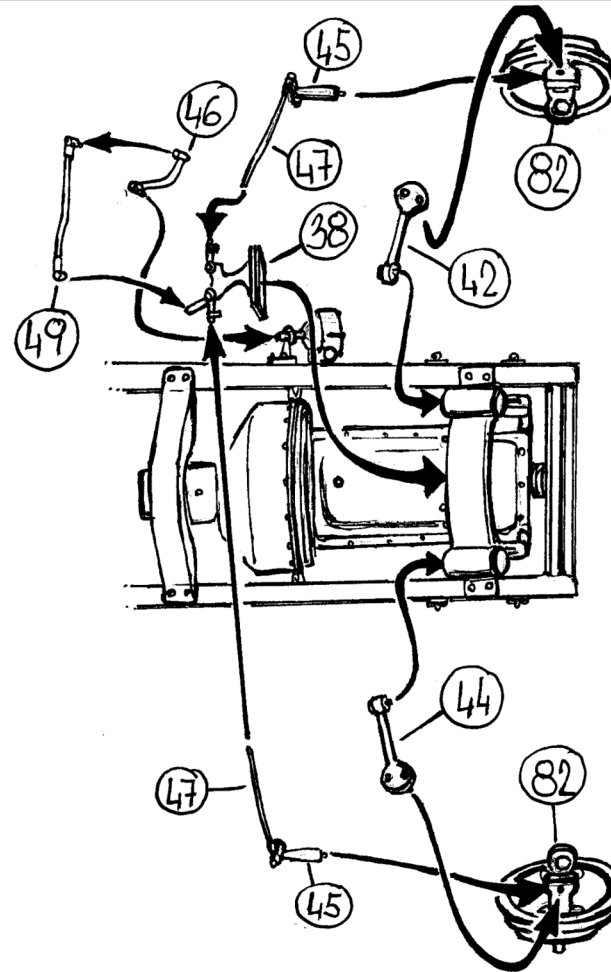

3

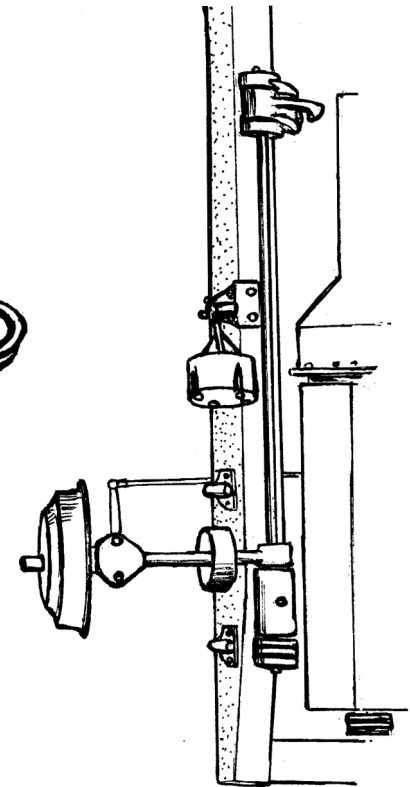
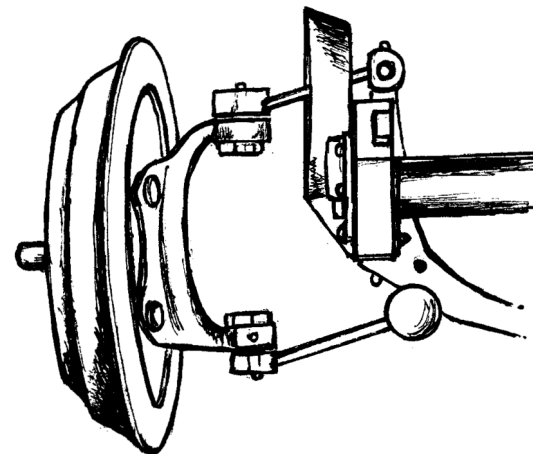

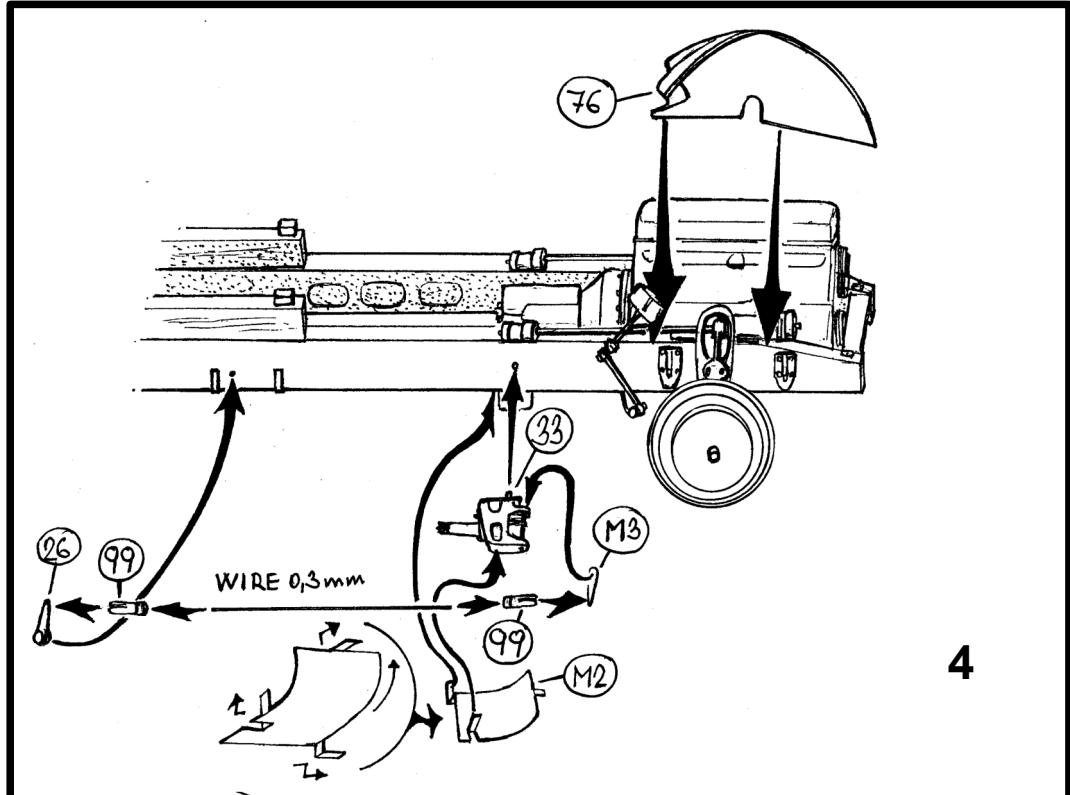

4

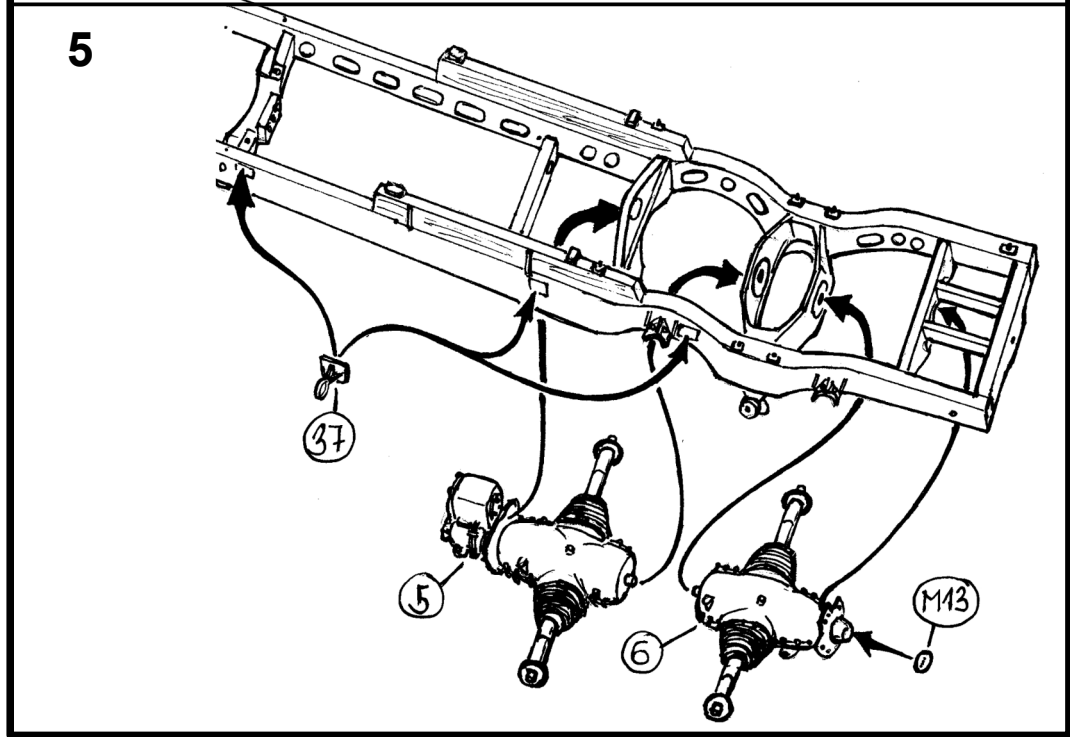

5

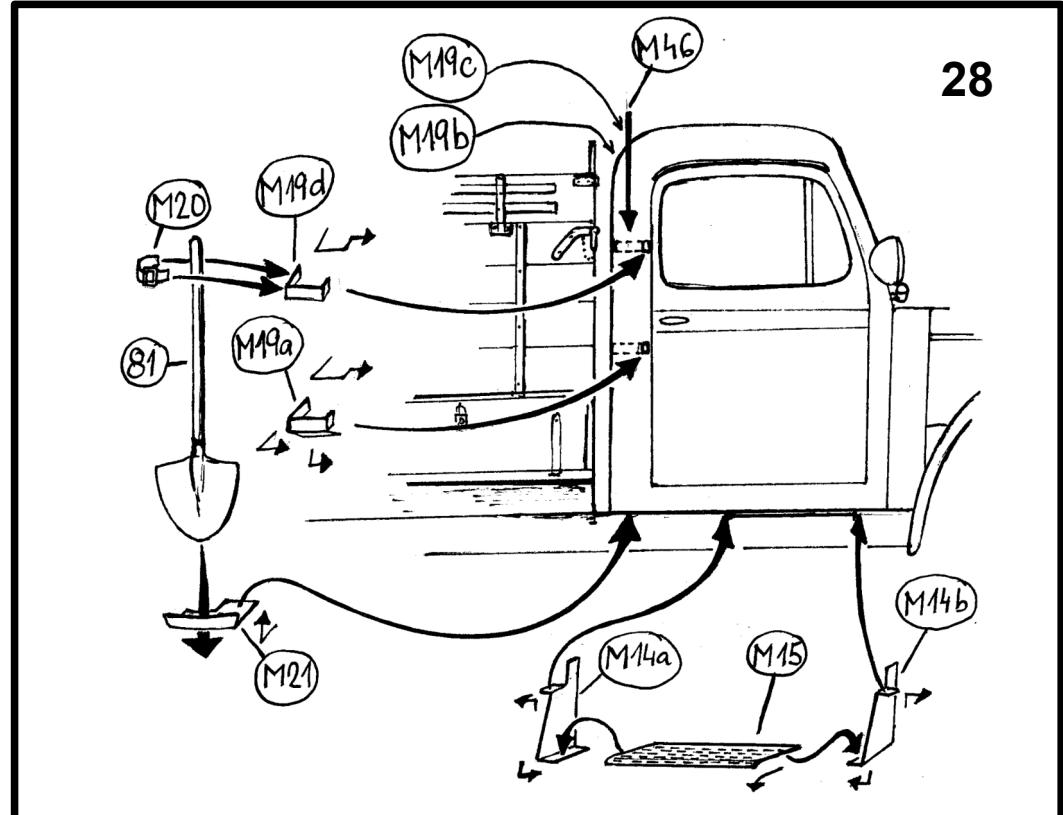

28

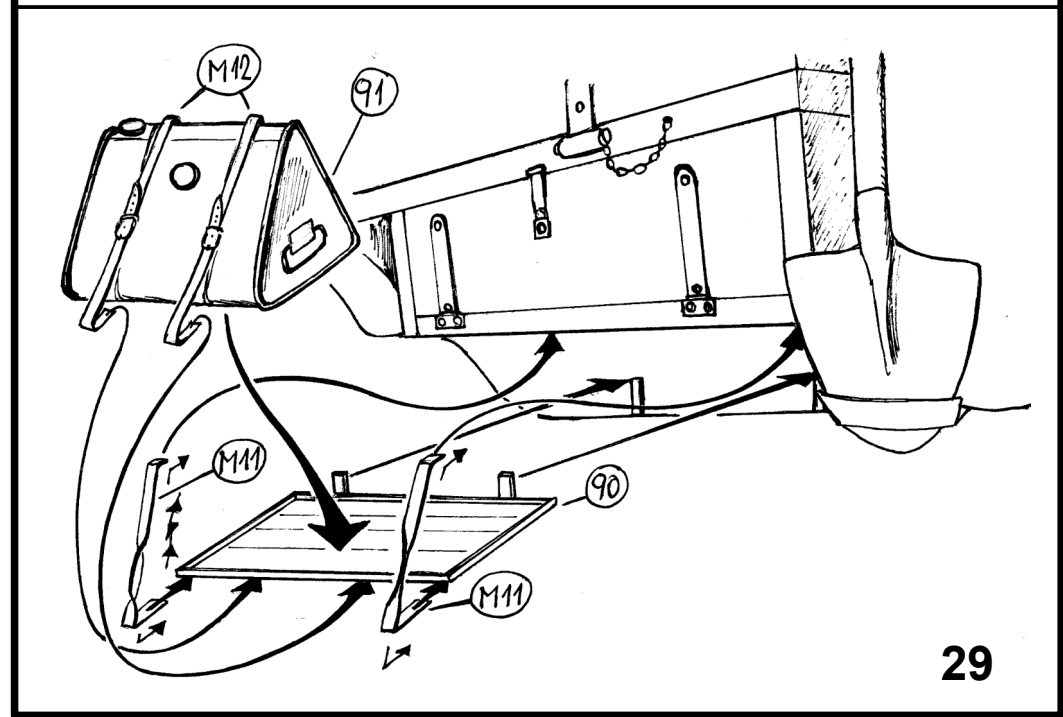

29

26

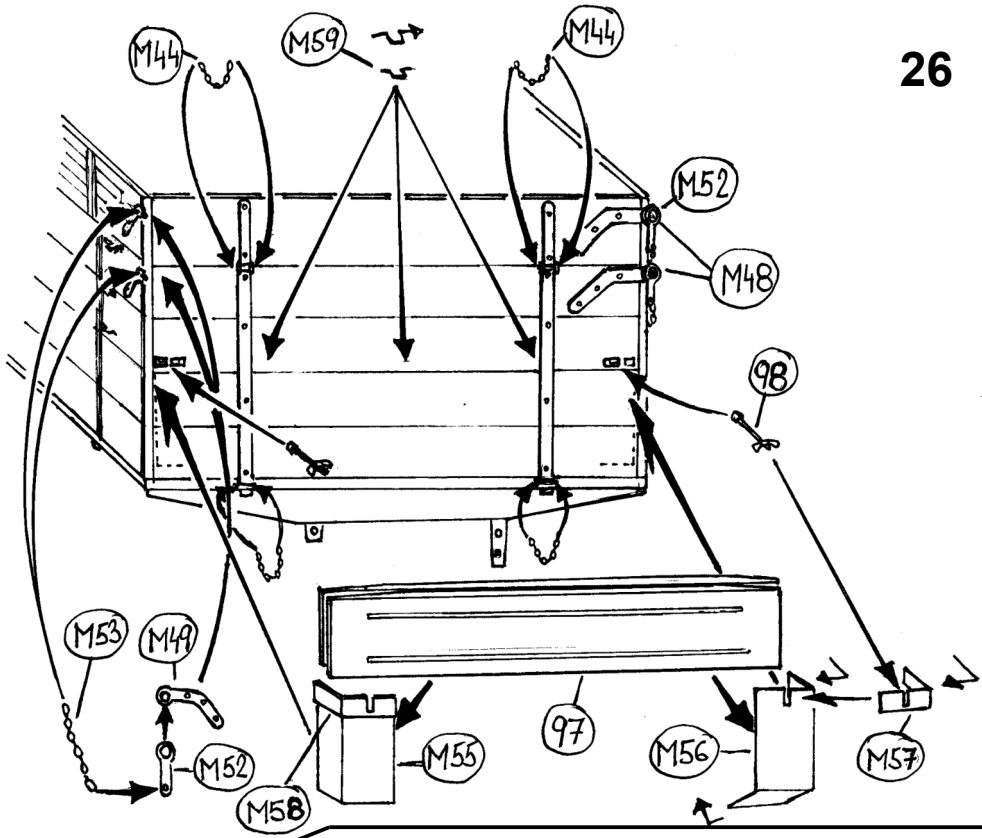

27

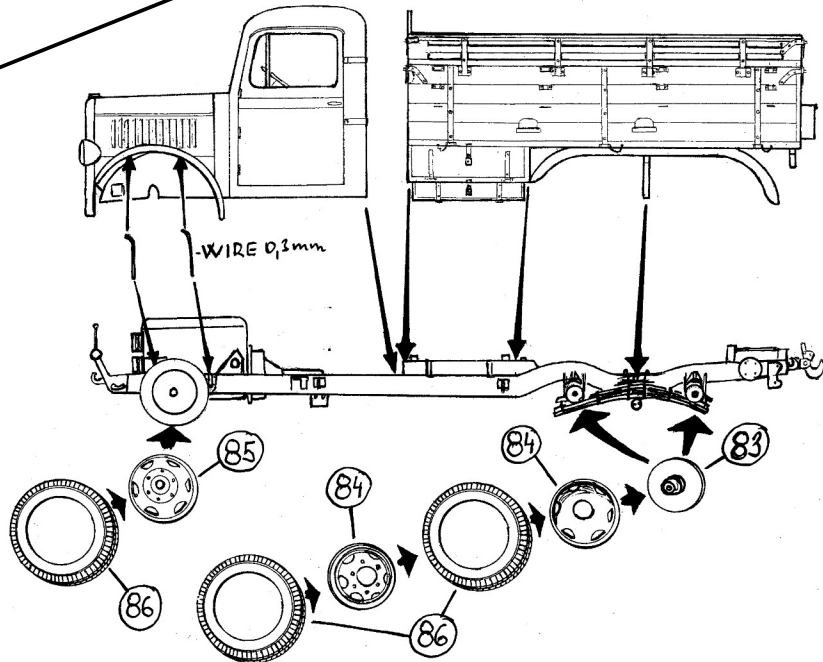

6

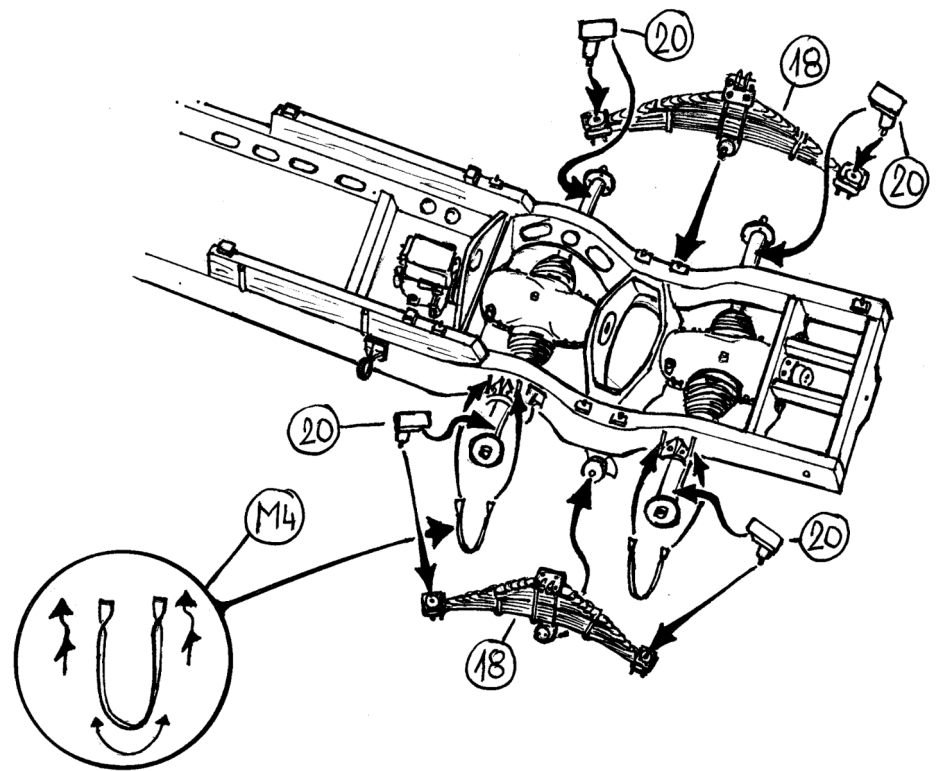

7

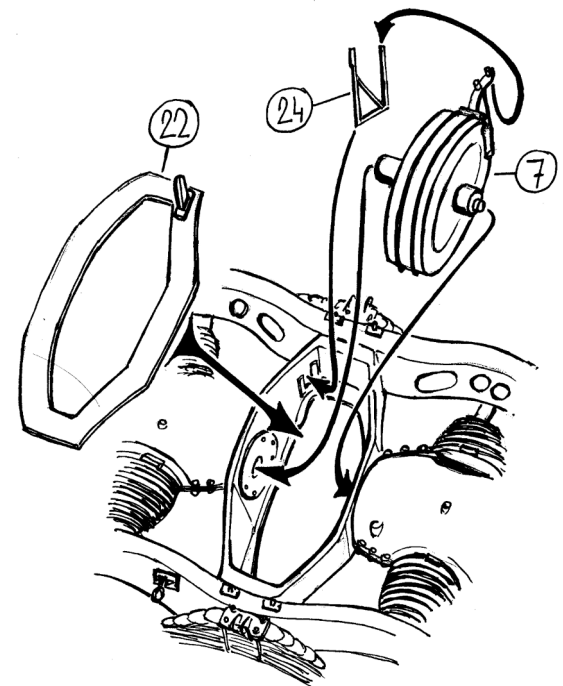

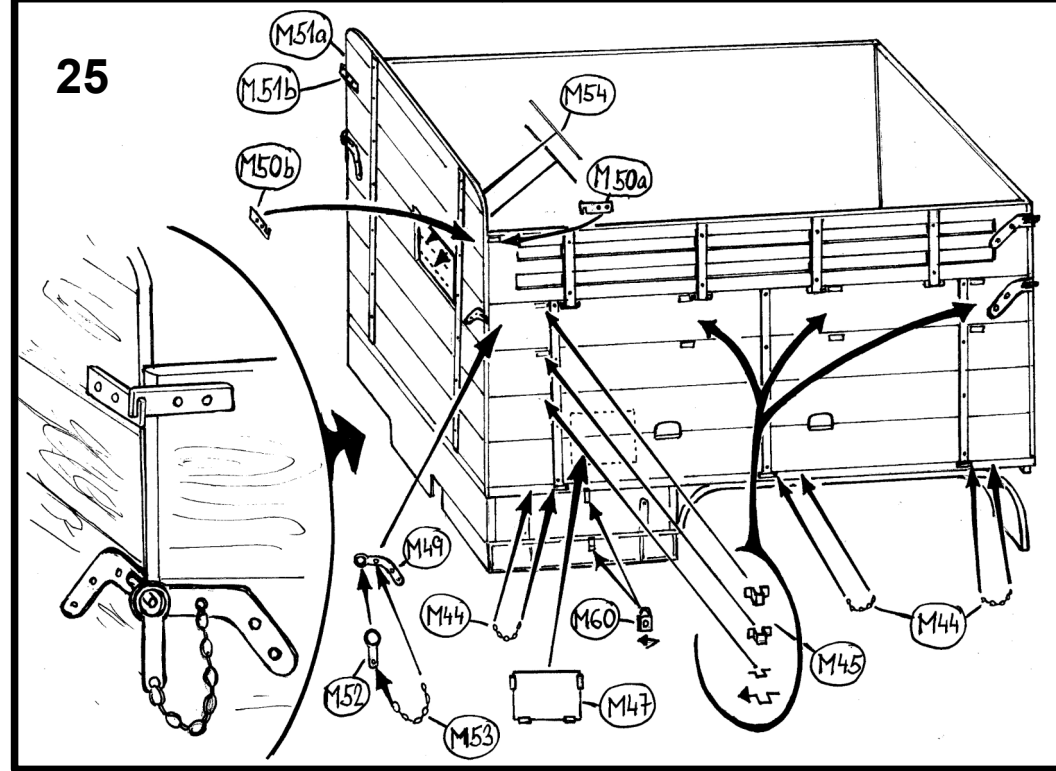
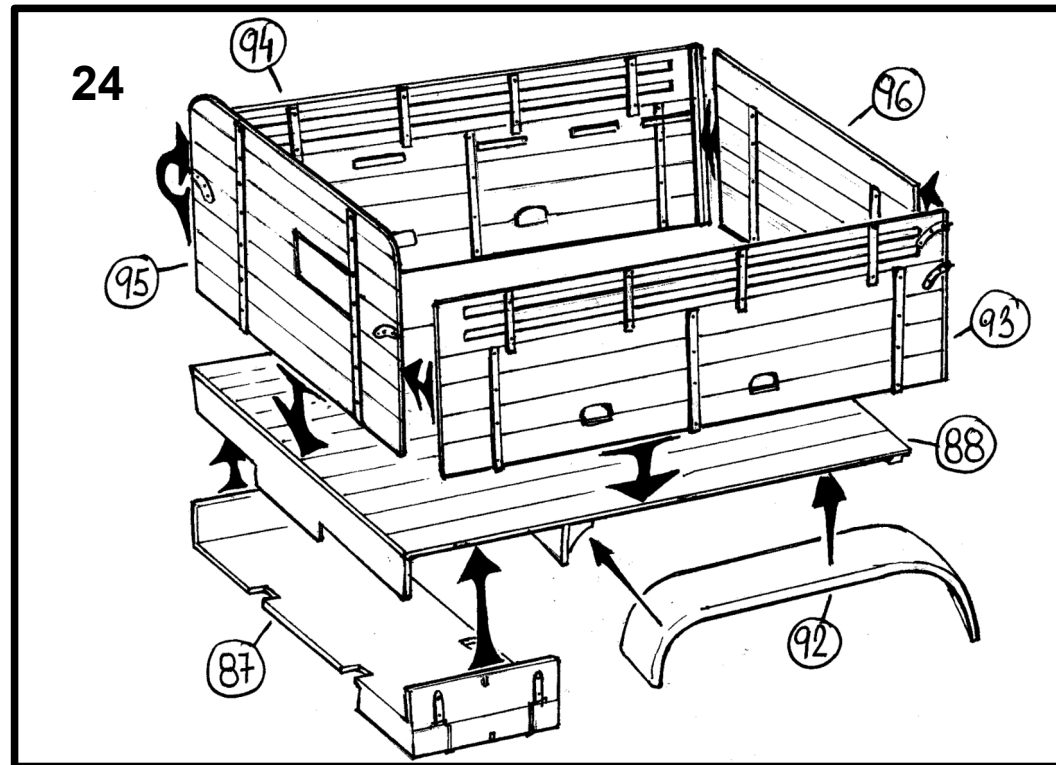
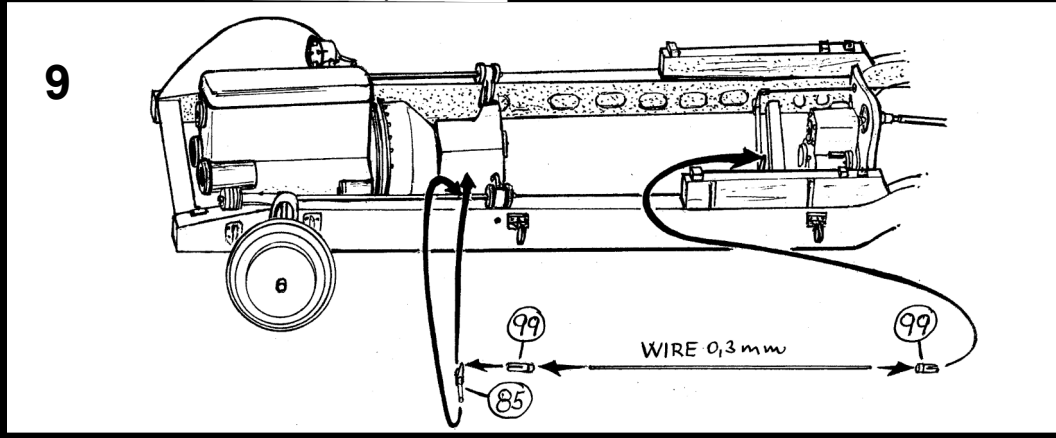
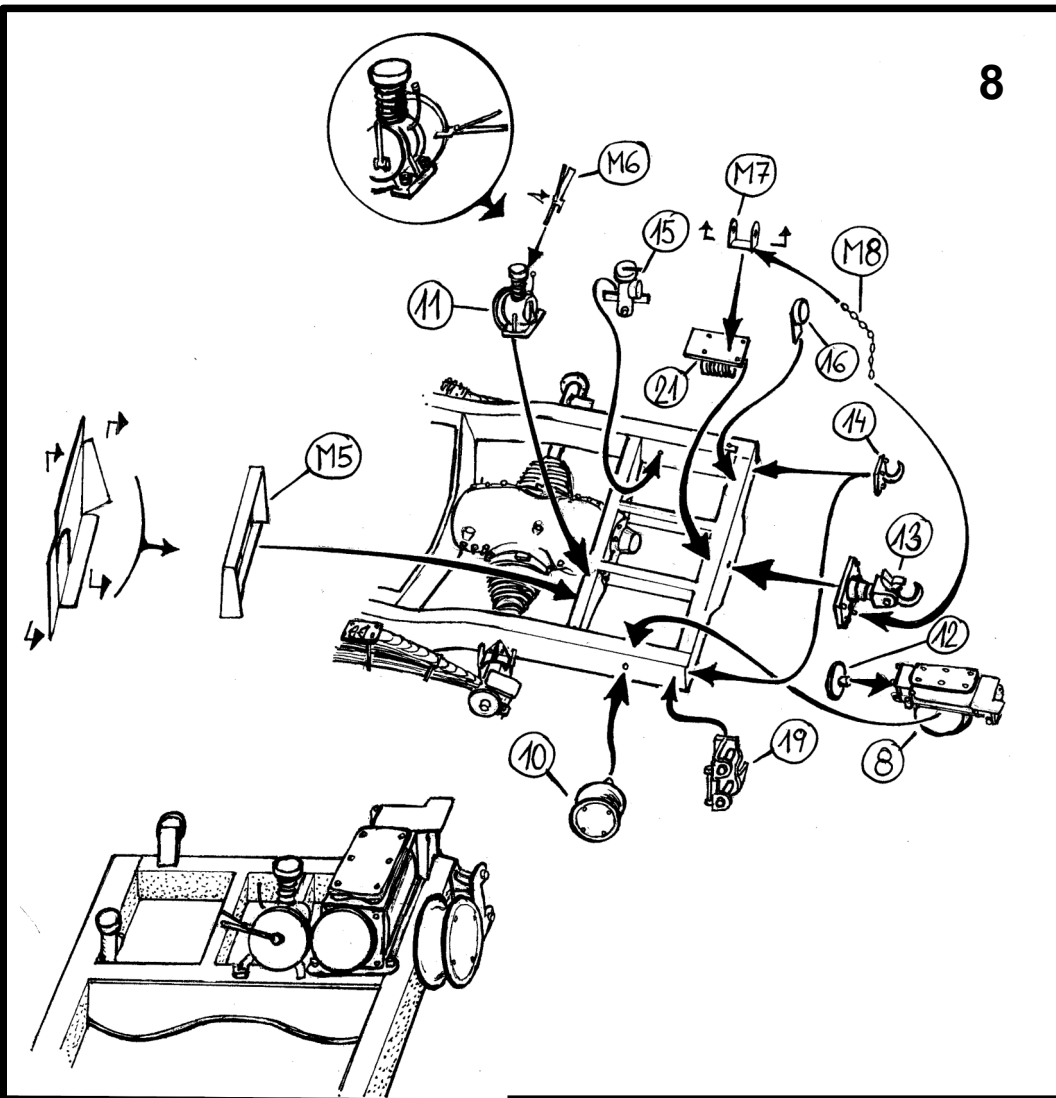

22

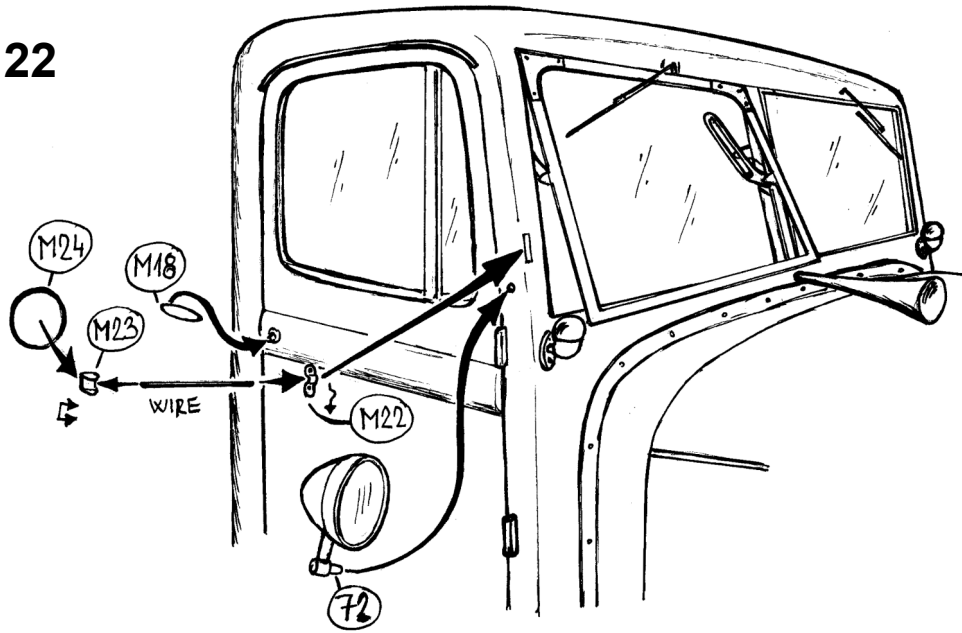

23

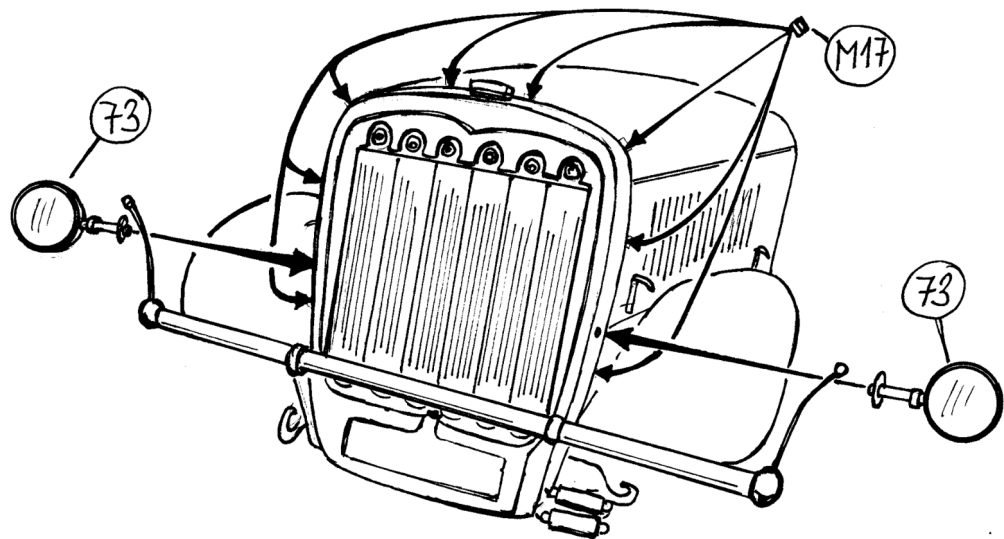

11

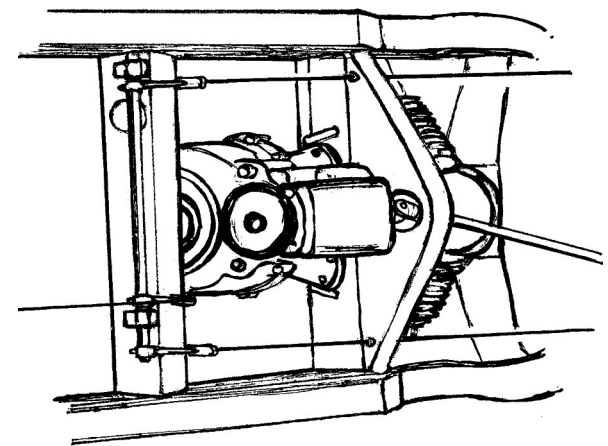
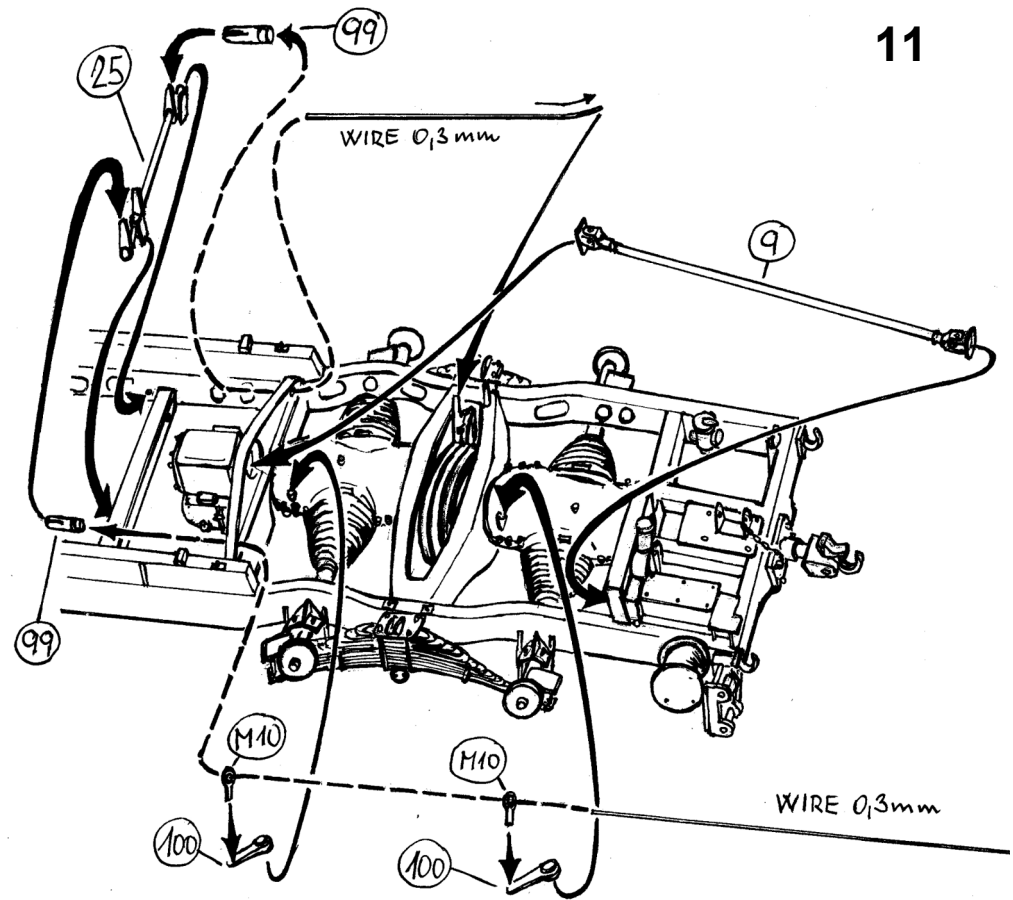

13

WIRE 0,3mm

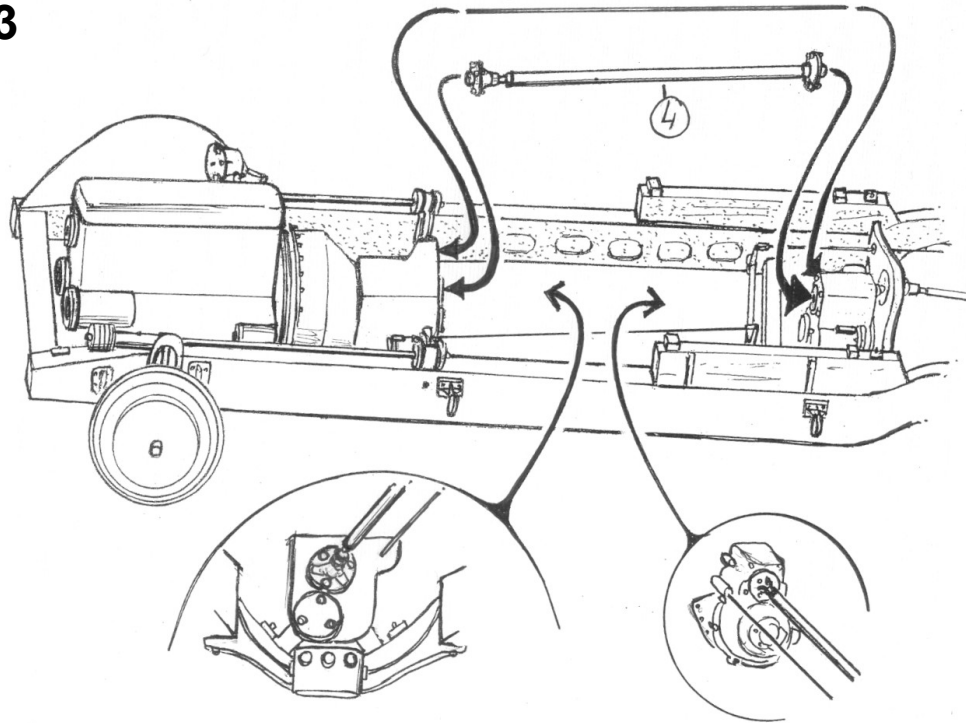

20

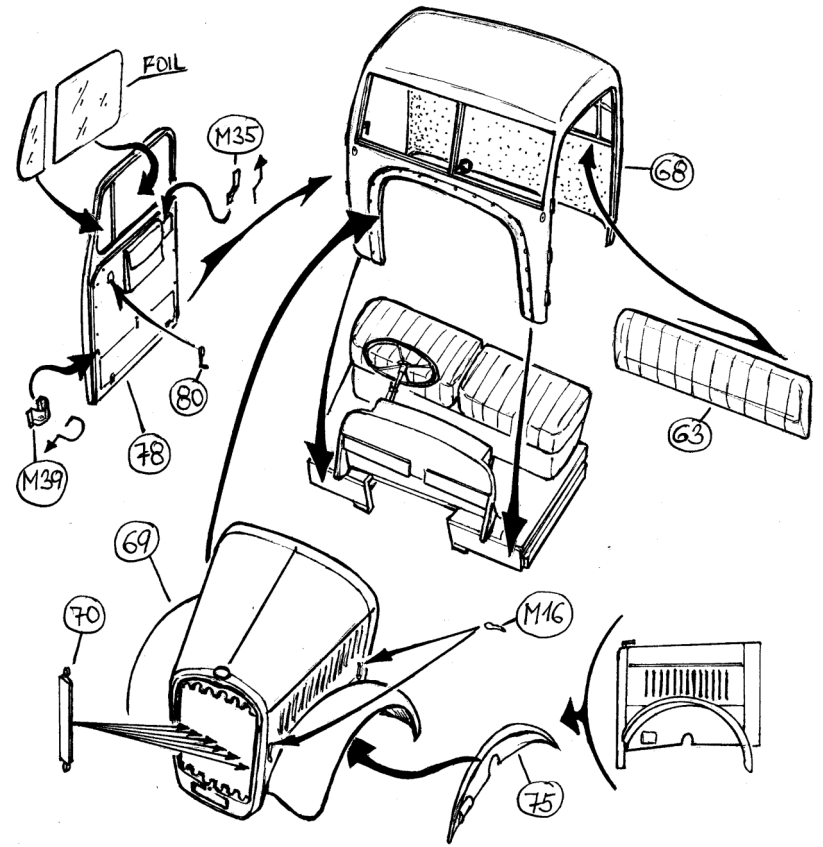

14

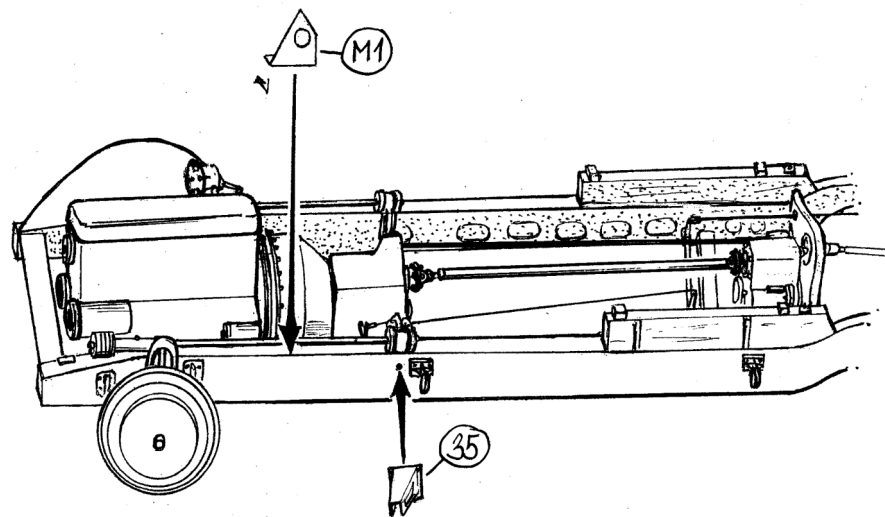

21

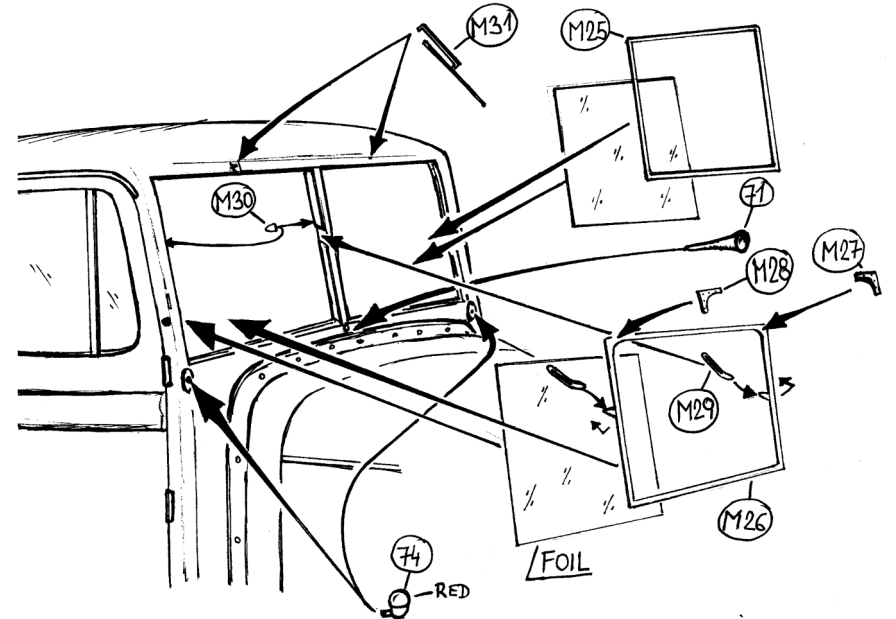

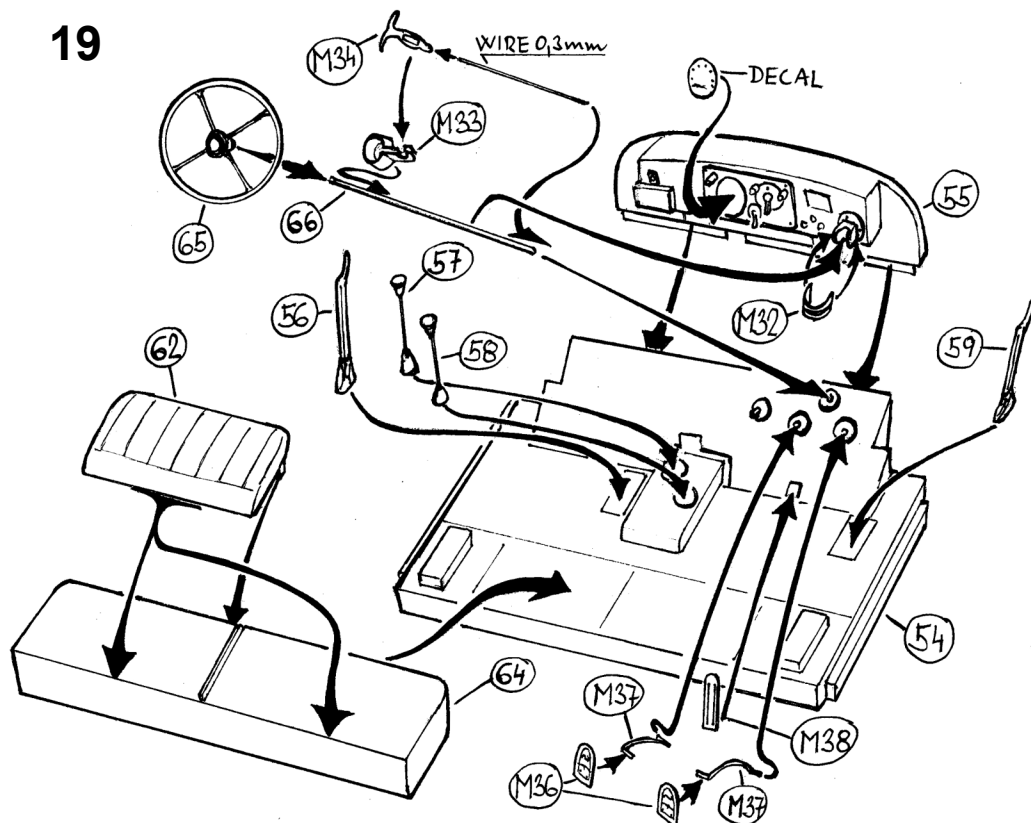

19

**COLOR**

Cabin floor – aluminium  
 Gearbox cover – khaki  
 Instrument panel – black  
 Seat and doors side – black leather  
 Steering wheel – black  
 Top of levers – black  
 Cover of lever – leather  
 Remnant of cabin – khaki

**ZBARVENÍ**

Podlaha – hliník  
 Středový tunel – khaki  
 Palubní deska – černá  
 Sedačka a vnitřní boky dveří – černá kůže  
 Volant – černá  
 Rukojeti pák – černá  
 Spodní kryty pák – kůže  
 Zbytek kabiny - khaki

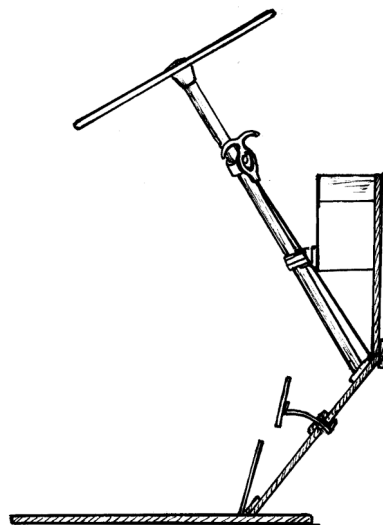

15

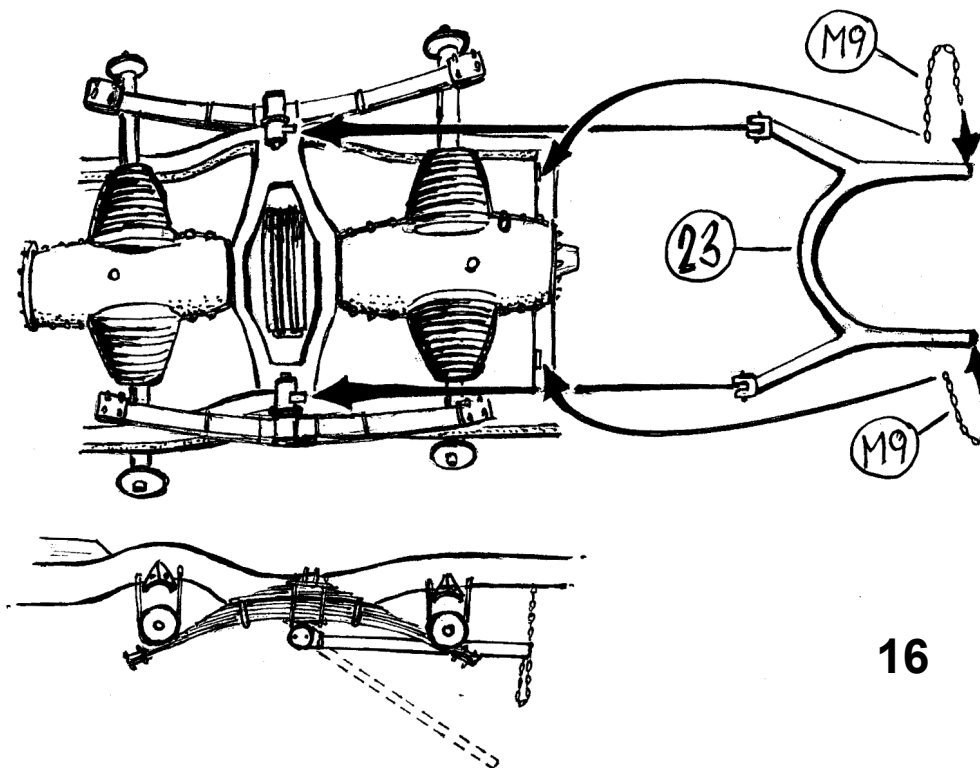
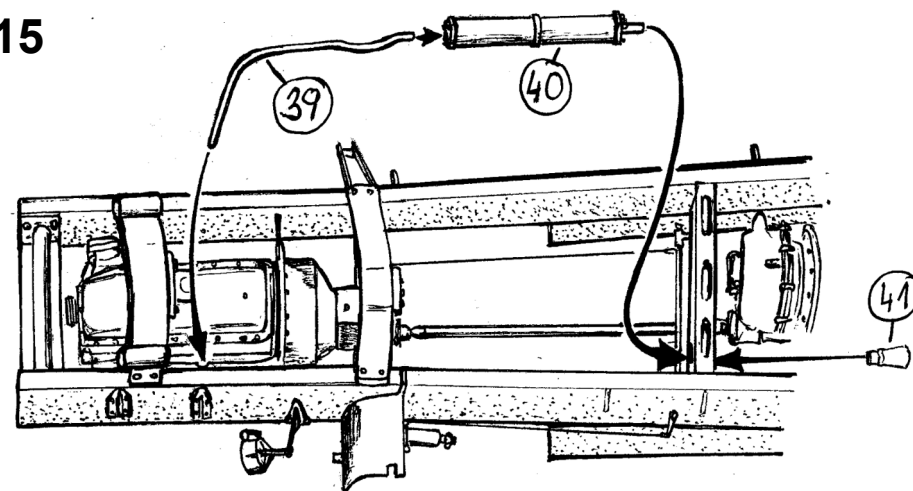

16

